

FIG. 2

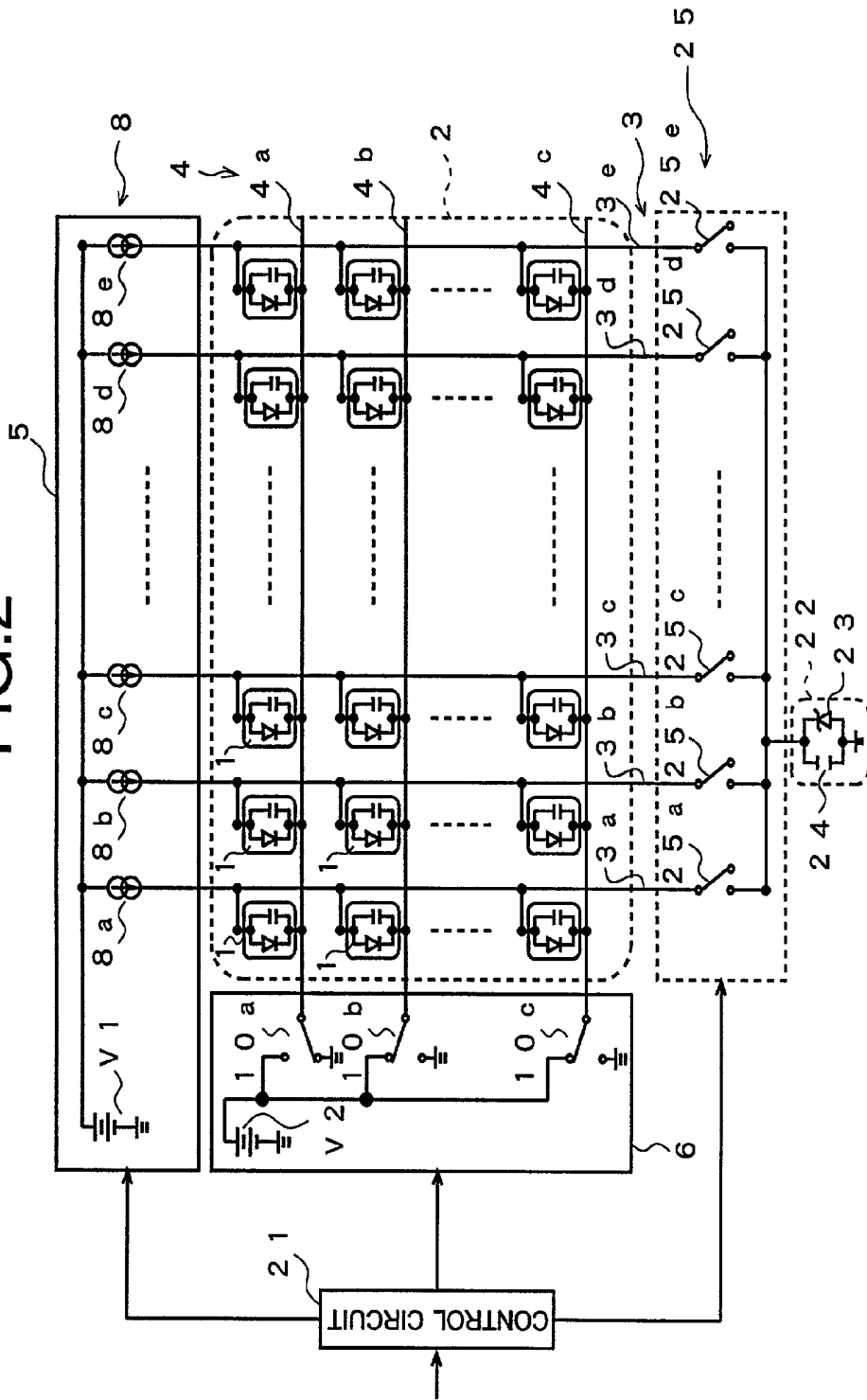

FIG.3

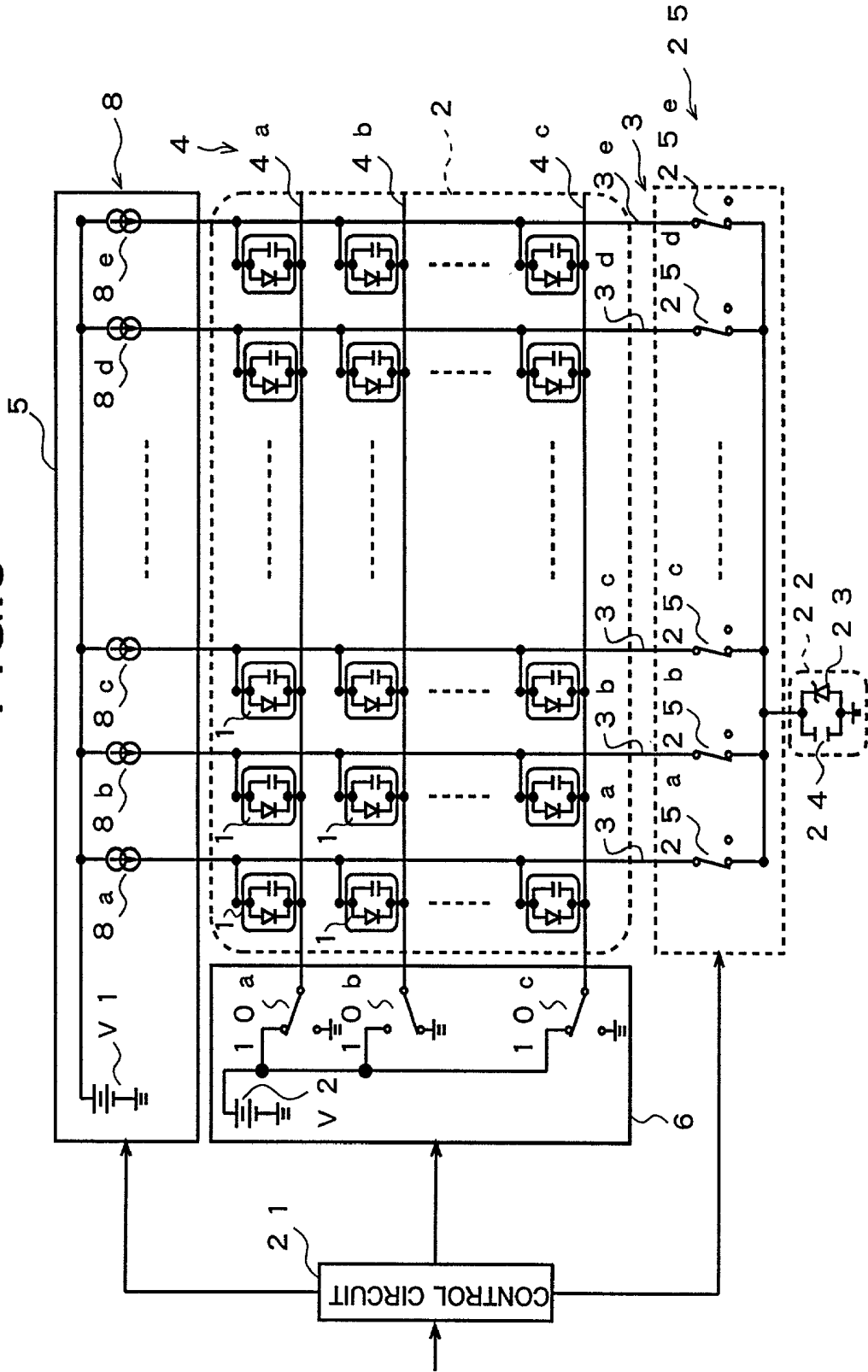

FIG. 4

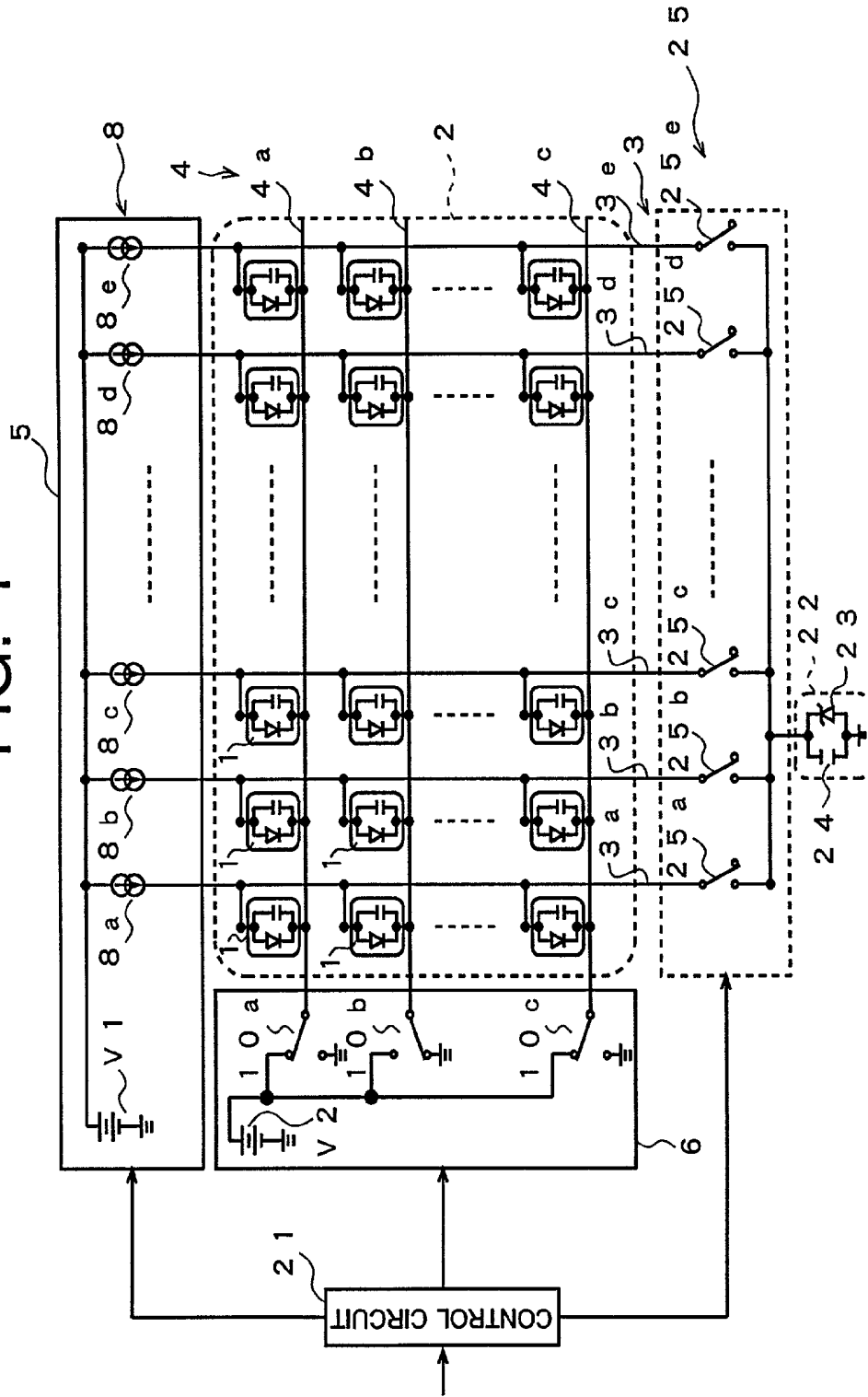

FIG. 5

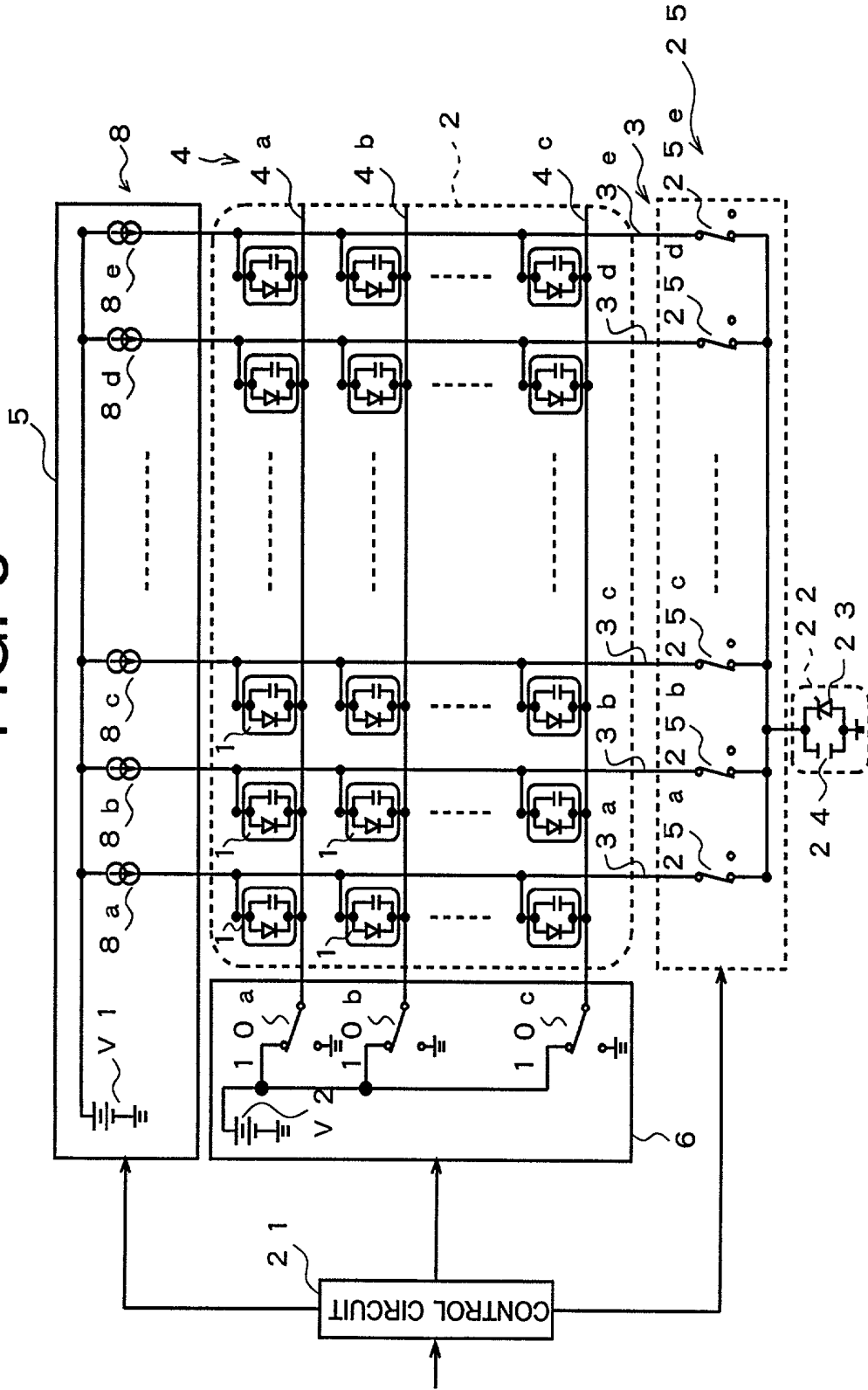

FIG. 6

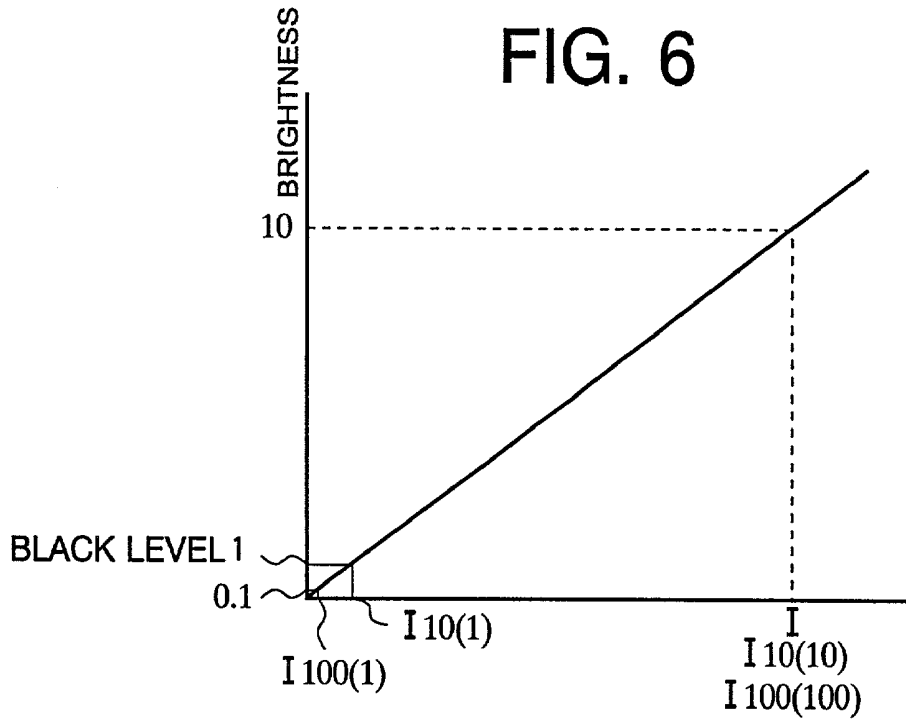

FIG. 7

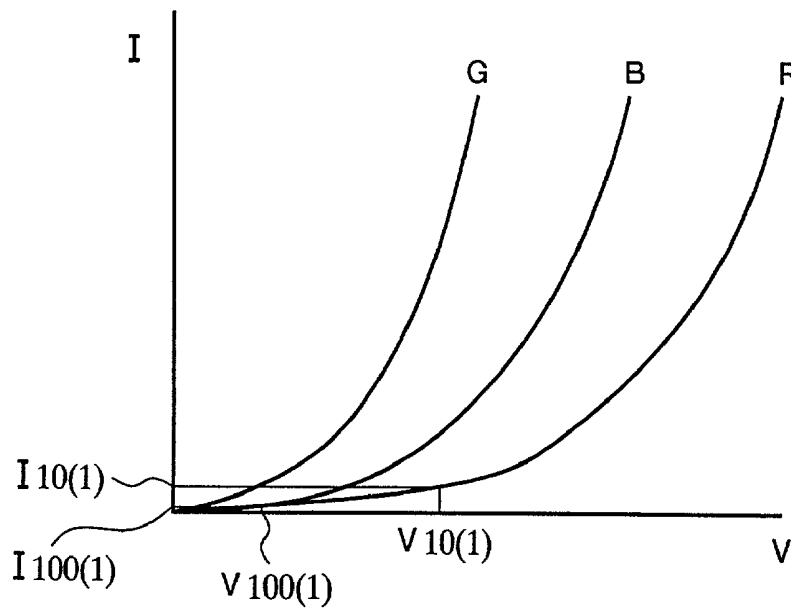

FIG. 8

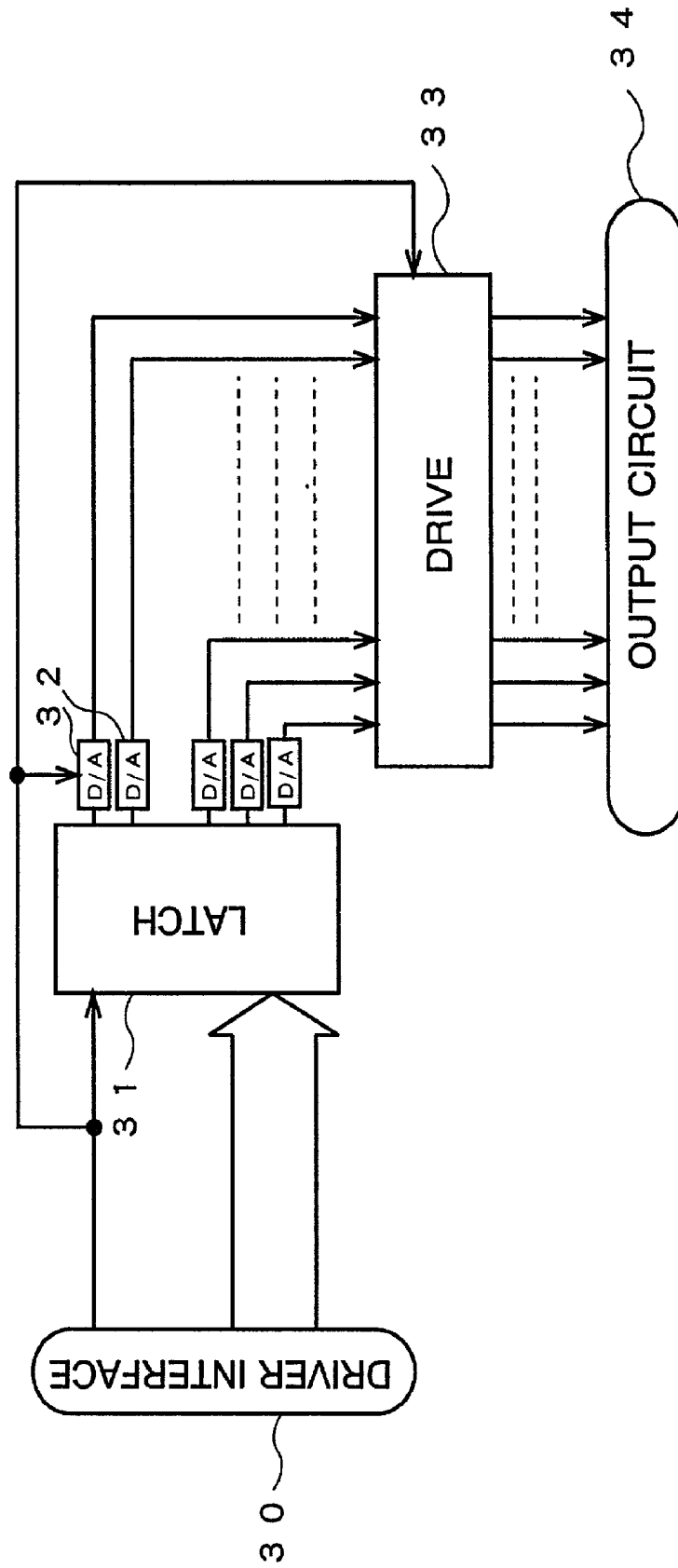

FIG. 9

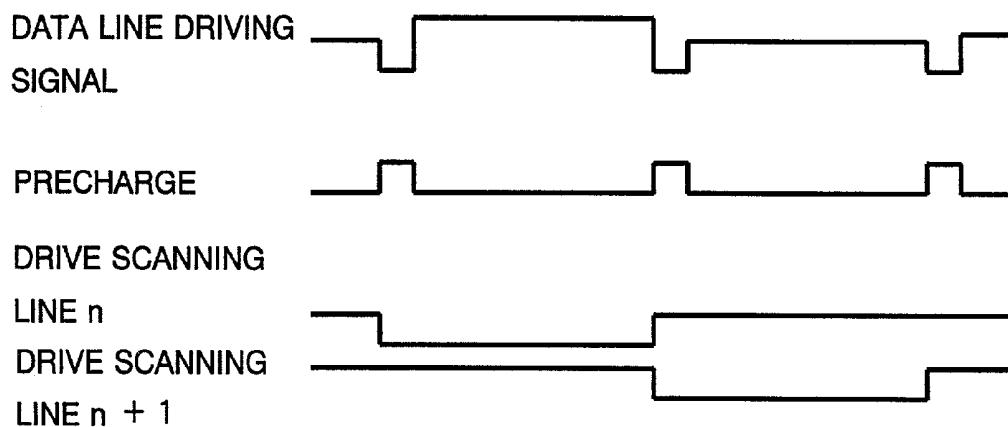
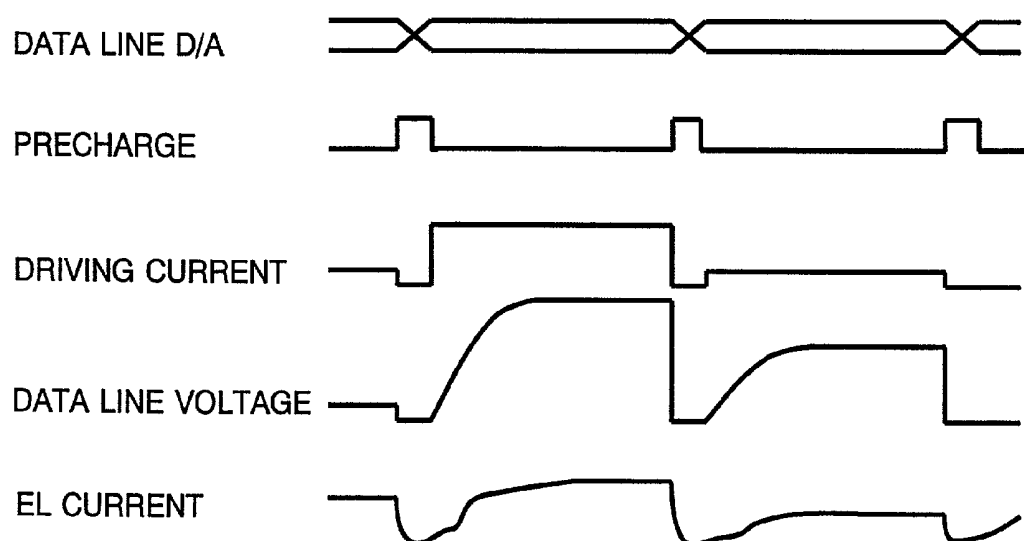

FIG. 10



ORGANIC EL DISPLAY DEVICE AND METHOD FOR DRIVING THE SAME

BACKGROUND OF THE INVENTION

[0001] 1. Field of the Invention

[0002] The present invention relates to an organic EL display device using organic EL (electro-luminescence) elements, and a method for driving the same.

[0003] 2. Description of the Related Art

[0004] In a luminescent display device using organic EL elements, the organic EL elements are arranged in a matrix pattern. The organic EL elements are illuminated by, for example, successively scanning rows of elements in a column direction by means of a scanning line driving circuit (row driving circuit) and selectively supplying a driving current to the elements in a specified row selected by the row driving circuit. The driving current is supplied by means of a data line driving circuit (column driving circuit). Such an organic EL display device has been attracting public attention as a self-emissive display device which does not require a backlight.

[0005] FIG. 1 is a diagram illustrating a conventional passive matrix type organic EL display device. A plurality of organic EL elements 1 are arranged in a matrix pattern to form an organic EL panel 2. For the sake of simplicity, each organic EL element 1 is shown in FIG. 1 to be composed only of a diode. However, each organic EL element 1 includes a parasitic capacitor, arranged in parallel with the element 1, which has a very large electrostatic capacitance with respect to the current flowing through the element 1.

[0006] As illustrated in FIG. 1, a column of organic EL elements 1 are connected by their anodes to each data line 3 (3a, 3b, 3c, 3d, 3e, etc.). The data lines 3 are connected to a column driving circuit 5. A row of organic EL elements 1 are connected by their cathodes to each scanning line 4 (4a, 4b, 4c, 4d, etc.). The scanning lines 4 are connected to a row driving circuit 6. The data lines 3 can be selectively connected to the ground level via shunt switches 7 (7a, 7b, 7c, 7d, 7e, etc.). In the column driving circuit 5, each signal current source 8 is connected to a data line 3 via drive switches 9 (9a, 9b, 9c, 9d, 9e, etc.). Each scanning line 4 is connected to a scanning switch 10 of a plurality of scanning switches (10a, 10b, 10c, 10d, etc.) of the row driving circuit 6. The scanning lines 4 are selectively connected to either a power source V2 or the ground level via the scanning switches 10. The drive switches 9 of the column driving circuit 5, the scanning switches 10 of the row driving circuit 6 and the shunt switches 7 are controlled by a control circuit 11.

[0007] In the conventional organic EL display device with such a configuration, the control circuit 11 receives image display data and controls the row driving circuit 6 to successively scan the scanning lines 4. While a scanning line 4 is selected, the column driving circuit 5 supplies a predetermined current as the driving current to a particular selected data line 3. In this way the organic EL element 1, which is connected to the selected scanning line 4 and the selected data line 3, is illuminated. For example, while the row driving circuit 6 is scanning the scanning line 4b, the organic EL elements 1 connected to the data lines 3b and 3c, among the organic EL elements 1 connected to the scanning

line 4b, can be illuminated by controlling the row driving circuit 6 to switch the scanning switch 10b to the ground side and switching the scanning switches 10a, 10c, 10d, etc., connected to the other scanning lines 4a, 4c, 4d, 4e, etc., to the power source V2 side. The column driving circuit 5 applies a power source V1 from the signal current source 8 to the data lines 3b and 3c by turning OFF the shunt switches 7b and 7c and turning ON the driving switches 9b and 9c. The column driving circuit 5 then connects the data lines 3a, 3d and 3e to a ground by turning ON the shunt switches 7a, 7d, 7e, etc., and turning OFF the driving switches 9a, 9d and 9e. At the same time the scanning line 4b is at the ground potential. In this way, the driving current supplied from the signal current source 8 to the data lines 3b and 3c, based on the potential difference between the power source V1 and the ground, flows through the organic EL elements 1 connected between the data lines 3b and 3c and the scanning line 4b. In this way the elements 1 are illuminated.

[0008] The elements 1 which are connected to the data lines 3b and 3c and to the other scanning lines 4a, 4c, 4d, 4e, etc., have their cathodes connected to the power source V2 via the scanning switches 10a, 10c, 10d, 10e. In this way the power source V1 is applied to the anodes of the elements 1 via the data lines 3b and 3c while the power source V2 is applied, as a reverse bias, to the cathodes of the elements 1 via the scanning lines 4a, 4c, 4d, 4e, etc. Since the voltages of the power source V1 and the power source V2 are set at similar levels, there is no voltage difference applied between the anode and the cathode of such elements 1. Consequently, the elements 1 are not illuminated.

[0009] The organic EL elements 1 which are connected to the scanning line 4b and to the other data lines 3a, 3d, 3e, etc., have their anodes and cathodes both grounded, and there is no voltage difference between them. Consequently, such elements 1 are not illuminated.

[0010] The power source V2 is applied to the cathodes and the ground potential is applied to the anodes of the organic EL elements 1 which are connected between the other data lines 3a, 3d, 3e, etc., and the other scanning lines 4a, 4c, 4d, etc. Consequently, a voltage difference in the opposite direction is applied to the elements 1. Therefore, a current does not flow through such elements 1, and the elements 1 are not illuminated. However, since a voltage difference in the opposite direction is applied to the elements 1, the parasitic capacitors of the elements 1 are charged in an opposite direction to the direction in which the parasitic capacitors of the illuminated elements 1 are charged.

[0011] In a case where the data lines 3a, 3d and 3e, which have not been driven in the previous scanning step, are driven in the next scanning step, in other words in a case where the data lines 3a, 3d and 3e, which have not been driven while scanning the scanning line 4b, are driven when the scanning operation proceeds to the scanning line 4c, a current of course flows through the organic EL elements 1 that are connected to the scanning line 4c and are to be illuminated. A current also flows through the organic EL elements 1 that are not connected to the scanning line 4c but have been charged in the reverse direction in the previous scanning step so as to cancel out the reverse charge. Therefore, it takes a long time to charge the organic EL elements 1 to be illuminated, and the current cannot be raised quickly.

[0012] In view of this, in the prior art, when the scanning operation by the row driving circuit 6 proceeds from the

scanning line **4b** to the next scanning line **4c**, all of the driving switches **9a**, etc., of the column driving circuit **5** are turned OFF. At the same time all of the scanning switches **10a**, etc., of the row driving circuit **6** and all of the shunt switches **7a**, etc., are connected to a ground or the power source. As a result the charge stored in the organic EL elements **1** is discharged. In this way, selected organic EL elements **1** are illuminated by applying a constant pixel current to the selected organic EL elements **1** after discharging all of the parasitic capacitors. The unnecessary charging of the organic EL elements **1** is consequently avoided.

[0013] While the current-voltage characteristics of the organic EL element **1** are conceptually close to those of a light emitting diode, the voltage at which the current rises is as high as about 5 to 10 V for the organic EL element **1**, whereas it is about 2 V for a light emitting diode. Moreover, unlike a light emitting diode, while the organic EL element **1** requires a very small current to be illuminated, the electrostatic capacitance of the parasitic capacitor arranged in parallel to the organic EL element **1** is very large, as described above. Therefore, while increasing the voltage applied to the organic EL element **1** to a voltage at which the current rises, the parasitic capacitor is charged. In this way the increase of the voltage for the organic EL element **1** to be illuminated is delayed.

[0014] As described above, in the conventional driving circuit, when the scanning operation proceeds from one scanning line to another, all of the scanning lines **4a**, etc., and all of the data lines **3a**, etc., are connected to a ground or the power source. In this way the parasitic capacitors present in the organic EL panel **2** are discharged completely, and the parasitic capacitor is charged from 0 V to a voltage at which illumination can be obtained in the following scanning step. Therefore, it requires a long time to charge the parasitic capacitor before the organic EL element **1** starts to be illuminated. Because the charge time is long, it is not possible to obtain an effective illumination time during which a current that is required to brightly illuminate the organic EL element **1** can be applied. Consequently, it is not possible to ensure a sufficient brightness.

[0015] In order to solve this problem, there has been proposed a method for driving a luminescent display in which an offset voltage is applied to, and charges, the light emitting elements during a period after the scanning of a scanning line is completed, and before the scanned line is switched to the next scanning line (Japanese Patent Laid-Open Publication No. Hei. 11-143429).

[0016] However, the conventional method for driving an organic EL display device requires a constant offset voltage source which is applied to all of the light emitting elements during a period after the scanning of a scanning line is completed and before the next scanning step.

SUMMARY OF THE INVENTION

[0017] The object of the present invention is to provide an organic EL display device, and a method for driving the same, in which a constant voltage source is not required and which is capable of being illuminated quickly with a simple circuit configuration. It is also the object to increase the brightness of the illumination while improving the current efficiency by collecting the charge of the parasitic capacitor.

[0018] An organic EL display device according to the present invention comprises: a plurality of organic EL elements arranged in a matrix pattern; a plurality of scanning lines each connected to a row of the organic EL elements; a plurality of data lines each connected to a column of the organic EL elements; a scanning line driving circuit for successively scanning the scanning lines; a data line driving circuit for applying a driving current to a selected data line in synchronization with the scanning operation of the scanning line driving circuit; a Zener diode capable of retaining a voltage in a range for a black level of the organic EL elements; a switch provided between each of the data lines and the Zener diode for either commonly connecting the data lines to the Zener diode or disconnecting the data lines from one another and from the Zener diode; and a control circuit for turning ON all of the switches to connect all of the data lines to one another and to the Zener diode when the scanning operation by the scanning line driving circuit proceeds from one scanning line to the next scanning line.

[0019] The method for driving an organic EL display device according to the present invention employ a device which device comprises: a plurality of organic EL elements arranged in a matrix pattern; a plurality of scanning lines each connected to a row of the organic EL elements; a plurality of data lines each connected to a column of the organic EL elements; a scanning line driving circuit for successively scanning the scanning lines; a data line driving circuit for applying a driving current to a selected data line in synchronization with the scanning operation by the scanning line driving circuit; a Zener diode capable of retaining a voltage in a range for a black level of the organic EL elements; and a switch provided between each of the data lines and the Zener diode. In the method, all of the switches are turned on to connect all of the data lines to one another and to the Zener diode so as to charge parasitic condensers of the organic EL elements to a voltage that is determined by the Zener diode when the scanning operation by the scanning line driving circuit proceeds from one scanning line to the next scanning line.

[0020] According to the present invention, when the scanning operation by the scanning line driving circuit proceeds from one scanning line to the next scanning line, all of the switches are turned ON. This is done so that the data lines are connected to one another and to commonly connect the data lines to the Zener diode immediately before applying a driving current to the data lines. Thus, the charge stored in the parasitic capacitors from pixels that have been illuminated during the previous scanning step is allowed to flow into the parasitic capacitors of all of the pixels via the data lines, so as to charge the parasitic capacitors. Thus, the organic EL element of each pixel is charged to a voltage that is determined by the Zener diode.

BRIEF DESCRIPTION OF THE DRAWINGS

[0021] FIG. 1 is a block diagram illustrating a conventional organic EL display device.

[0022] FIG. 2 is a block diagram illustrating an organic EL display device according to an embodiment of the present invention.

[0023] FIG. 3 is a block diagram illustrating an operation of the embodiment.

[0024] FIG. 4 is another block diagram illustrating an operation of the embodiment.

[0025] FIG. 5 is still another block diagram illustrating an operation of the embodiment.

[0026] FIG. 6 is a diagram illustrating a retained voltage of a voltage retaining circuit.

[0027] FIG. 7 is another diagram illustrating a retained voltage of the voltage retaining circuit.

[0028] FIG. 8 is a block diagram illustrating an example of a circuit configuration of a data line driving circuit.

[0029] FIG. 9 is a timing chart illustrating a column-row timing.

[0030] FIG. 10 is a timing chart illustrating a column timing.

DETAILED DESCRIPTION OF THE PREFERRED EMBODIMENTS

[0031] Embodiments of the present invention will now be described with reference to the accompanying drawings. FIG. 2 is a circuit diagram illustrating an organic EL display device according to an embodiment of the present invention. Organic EL elements 1 are arranged in a matrix pattern, forming an organic EL panel 2. Each organic EL element 1 includes a diode and a parasitic capacitor connected in parallel to the diode. A column of organic EL elements 1 are connected by their anodes to each data line 3 (3a, 3b, 3c, 3d, 3e, etc.). The data lines 3 (3a, 3b, 3c, 3d, 3e, etc.) extend in the column direction in parallel with one another. A row of organic EL elements 1 are connected by their cathodes to each scanning line 4 (4a, 4b, 4c, etc.). The scanning lines 4 (4a, 4b, 4c, etc.) extend in the row direction in parallel with one another. The data lines 3 (3a, 3b, 3c, 3d, 3e, etc.) and the scanning lines 4 (4a, 4b, 4c, etc.) are made of a transparent conductive film such as ITO (Indium-Tin-Oxide).

[0032] Each data line 3 (3a, 3b, 3c, 3d, 3e, etc.) is connected to a data line driving circuit 5. In the data line driving circuit 5, signal current sources 8 (8a, 8b, 8c, 8d, 8e, etc.) are connected to the data lines 3 (3a, 3b, 3c, 3d, 3e, etc.) respectively, and the signal current sources 8 (8a, 8b, 8c, 8d, 8e, etc.) are connected to the power source V1.

[0033] The scanning lines 4 (4a, 4b, 4c, etc.) are connected to a scanning line driving circuit 6. In the scanning line driving circuit 6, switches 10a, 10b, 10c, etc., are connected to the scanning lines 4 (4a, 4b, 4c, etc.) respectively. One end of each of the switches 10a, 10b, 10c, etc., is connected to a power source V2, and the other end thereof is connected to the ground.

[0034] The data lines 3 (3a, 3b, 3c, 3d, 3e, etc.) are commonly connected to a voltage retaining circuit 22 via switches 25 (25a, 25b, 25c, 25d, 25e, etc.) respectively. The voltage retaining circuit 22 includes a Zener diode 23 and a capacitor 24 connected in parallel to the Zener diode 23. An anode of the Zener diode 23 is connected to the data lines 3 (3a, 3b, 3c, 3d, 3e, etc.), and a cathode of the Zener diode 23 is connected to the ground. The switches 25 (25a, 25b, 25c, 25d, 25e, etc.) turns ON/OFF the connection between the data lines 3 (3a, 3b, 3c, 3d, 3e, etc.), respectively, and the voltage retaining circuit 22. The potential of the Zener diode

23 is as high a potential as possible so that it is determined to be a black level of each color.

[0035] The output of the signal current sources 8 (8a, 8b, 8c, 8d, 8e, etc.) of the data line driving circuit 5, the ON/OFF of the switches 10a, 10b, 10c, etc., of the scanning line driving circuit 6, and the ON/OFF of the switches 25 (25a, 25b, 25c, 25d, 25e, etc.) of the switch circuit are controlled by a control circuit 21 to which illumination data is input.

[0036] The organic EL display device includes the organic EL panel 2, the data line driving circuit 5, the scanning line driving circuit 6, a switch circuit 25, and the voltage retaining circuit 22, each with a configuration as illustrated in FIG. 2 for each green (G), blue (B) and red (R) illumination color.

[0037] Next, the operation of the organic EL display device of the present embodiment with such a configuration will be described along with the control operation by the control circuit 21. When the operation of the scanning line driving circuit 6 is switched from the scanning of the scanning line 4c to the scanning of the scanning line 4a, the control circuit 21 turns the switch 10a of the scanning line driving circuit 6 to the ground side while turning the other switches 10b, 10c, etc., to the power source V2 side. This is illustrated in FIG. 2. Then, in a case where the organic EL elements 1 connected to the data lines 3b and 3c, among the organic EL elements 1 connected to the scanning line 4a, are illuminated, an illumination level current is output from the signal current sources 8b and 8c.

[0038] In this way, each of the signal current sources 8b and 8c produce a current flowing through one of the organic EL elements 1 connected between the data lines 3b and 3c and the scanning line 4a. The current flows from the data lines 3b and 3c to the scanning line 4a, thereby illuminating the organic EL elements 1. At the same time, the parasitic capacitor of each of the illuminated organic EL elements 1 is charged in the forward direction. For the other scanning lines 4b and 4c, the switches 10b and 10c are connected to the power source V2 side. Therefore, by setting the voltage of the power source V1 and the voltage of the power source V2 to a similar level the organic EL elements 1 connected between the data lines 3b and 3c and the other scanning lines 4b and 4c will not be illuminated. The parasitic capacitors of these organic EL elements 1 are charged to a reverse bias potential according to the magnitude of the driving current. The organic EL elements 1 connected between the other data lines 3a, 3d and 3e and the scanning line 4a will not be illuminated because the signal current sources 8a, 8d and 8e do not supply the driving current. The parasitic capacitors of these organic EL elements 1 are not charged/discharged. The anodes of the organic EL elements 1 which are connected between the other scanning lines 4b and 4c and the other data lines 3a, 3d and 3e are not supplied with a driving current and the cathodes of the organic EL elements 1 are connected to the power source V2. In this way these organic EL elements 1 are reverse biased with a voltage difference in the reverse direction applied to the opposite sides of the organic EL elements 1. Thus, since these organic EL elements 1 are reverse biased, the organic EL elements 1 will not be illuminated. The parasitic capacitors of these organic EL elements 1 are charged to a negative reverse bias potential.

[0039] Then, when the scanning operation proceeds from the scanning line 4a to the scanning line 4b, the control

circuit **21** connects the switch **10b** of the scanning line driving circuit **6** to the ground while connecting the other switches **10a** and **10c** to the power source **V2** side. This is illustrated in **FIG. 3**. Moreover, the switches **25** (**25a**, **25b**, **25c**, **25d**, **25e**, etc.) are all connected to the voltage retaining circuit **22**. As a result, all of the data lines **3** (**3a**, **3b**, **3c**, **3d**, **3e**, etc.) are connected to one another, whereby charges flow from the illuminated pixels to all the pixels via the data lines **3** (**3a**, **3b**, **3c**, **3d**, **3e**, etc.). Thus, the parasitic capacitors of all of the organic EL elements **1** are charged with the charges flowing into the parasitic capacitors, whereby all of the data lines **3** (**3a**, **3b**, **3c**, **3d**, **3e**, etc.) are at a potential that is determined by the Zener diode **23** of the voltage retaining circuit **22**. Moreover, the capacitor **24** connected in parallel to the Zener diode **23** is also charged to the same potential as the data lines **3** (**3a**, **3b**, **3c**, **3d**, **3e**, etc.). The potential of the Zener diode **23** is as high a potential as possible such that it is determined to be a black level of each color. Thus, the parasitic capacitor of the organic EL element **1** of each pixel is charged to a potential that is determined by the Zener diode **23**.

[0040] Then, as illustrated in **FIG. 4**, the control circuit **21** turns OFF all of the switches **25** (**25a**, **25b**, **25c**, **25d**, **25e**, etc.) so as to disconnect the data lines **3** (**3a**, **3b**, **3c**, **3d**, **3e**, etc.) from one another while disconnecting the data lines from the voltage retaining circuit **22**. At the same time, in a case where the organic EL elements **1** to be illuminated, among the organic EL elements **1** connected to the scanning line **4b**, are those organic EL elements **1** connected to the data lines **3d** and **3e** and the scanning line **4b**, the driving current is allowed to flow from the signal current sources **8d** and **8e**, with the other signal current sources **8a**, **8b** and **8c** being turned OFF. As a result, a potential difference based on the current value of the signal current sources **8d** and **8e** is applied in the forward direction to the organic EL elements **1** connected to the data lines **3d** and **3e** and the scanning line **4b**. In this way these organic EL elements **1** are illuminated. In such a case, since the parasitic capacitors of the organic EL elements **1** have already been charged to a potential that is determined by the potential of the Zener diode **23**, the parasitic capacitors need to be charged with only a small amount of charge to illuminate the organic EL elements **1**. Therefore, these pixels are illuminated very quickly after the switch **25** is turned OFF. For pixels to which a signal current is not supplied, the parasitic capacitors of the organic EL elements **1** are charged with either no charge or with a reverse charge (reverse bias charge), as described above.

[0041] Then, when the scanning operation proceeds to the next scanning line, the switches of the next scanning line (not shown in **FIG. 5**) are grounded, and all of the switches **25** (**25a**, **25b**, **25c**, **25d**, **25e**, etc.) are connected to the voltage retaining circuit **22** side, as illustrated in **FIG. 5**. Thus, charges flow from the illuminated pixels to all the pixels, whereby the parasitic capacitors of the organic EL elements **1** of all of the pixels are charged to a potential that is determined by the potential of the Zener diode **23**. In such a case, even if the charge stored in the parasitic capacitors of the organic EL elements **1** of the illuminated pixels is not sufficient to charge the parasitic capacitors of the organic EL elements **1** of all of the pixels to the potential determined by the Zener diode **23**, a charge is also supplied from the capacitor **24**. In this way the parasitic capacitors of all of the pixels are charged with a charge that is determined by the potential of the Zener diode **23**.

[0042] Therefore, when the data line driving circuit **5** drives a predetermined data line with a signal from the control circuit **21**, the voltage difference between the opposite sides of each of the organic EL elements **1** of those pixels to be illuminated increases to a desired brightness level very quickly. This is because the parasitic capacitors of the organic EL elements **1** of all of the pixels have been charged to a black level.

[0043] As described above, according to the present embodiment, it is possible, with the simple circuit configuration including the Zener diode, the capacitor, and the ON/OFF switch, without a constant voltage source, to quickly illuminate the organic EL elements **1**. In this way a sufficiently high current can be applied to the organic EL elements **1**, thus obtaining a high level of brightness. Moreover, the charge with which the organic EL elements **1** are charged to a black level is supplied from the parasitic capacitors of those organic EL elements **1** that have been illuminated in the previous scanning step. Thus, the charge to a black level is done by using the collected charge, thereby making effective use of the charge, and avoiding the wasteful current consumption for charging the parasitic capacitors.

[0044] While the voltage retaining circuit **22** includes the Zener diode **23** and the capacitor **24** connected in parallel to each other in the present embodiment, the capacitor **24** does not always have to be provided. The parasitic capacitor of the organic EL element **1** of each pixel has a large capacitance value. Because of this the large amount of charge stored in the parasitic capacitors of the organic EL elements **1** of the pixels that have been illuminated in the previous scanning step is supplied to the parasitic capacitors of all of the organic EL elements **1** through the data lines **3** (**3a**, **3b**, **3c**, **3d**, **3e**, etc.). Therefore, the capacitor **24** does not need to be charged. However, in a case where an image to be displayed is such that only a small number of pixels are illuminated, for example, it is preferred that the capacitor **24** is provided. In this case the capacitor **24** is also charged with the charge stored in the parasitic capacitors of the pixels illuminated in the previous scanning step so that the capacitor **24** also supplies a charge in the following scanning step. In this way the organic EL element **1** of each pixel is stably charged to a black level.

[0045] As described above, in the present embodiment, the Zener diode **23** connected in parallel with the voltage retaining capacitor **24** generating a bias voltage is charged by using a charge that has been stored in the parasitic capacitors of the pixels in the previous scanning step. The voltage of the organic EL element **1** when OFF, though it varies substantially depending upon the material used for the organic EL element **1**, is typically 5 to 10 V. This voltage is substantially larger than that of a light emitting diode, which is a commonly-employed current light emitting element. On the other hand, an organic EL element inevitably has a relatively large parasitic capacitor due to its structure. Therefore, with an organic EL display driving circuit of a current driving type that outputs a constant current, it takes a long time before the voltage increases to a level sufficient to obtain a desired brightness. In this way the effective illumination time for which a pixel is illuminated with a desired brightness is reduced. In contrast, according to the present embodiment, when the scanning operation proceeds to the next scanning line, an organic EL element, immediately

before it is driven, is charged with the element's black level voltage. That is to say, an organic EL element is charged with a voltage of a level that is slightly lower than that of the voltage at which the element is illuminated, whereby the element is illuminated within a short period of time upon application of a driving current thereto. According to the present invention, in order to drive the organic EL elements in this way, instead of a constant voltage source, the charge, which has been stored in the parasitic capacitors of the organic EL elements in the previous scanning step, is collected and used to charge the parasitic capacitor of each organic EL element. This takes place when the operation proceeds to the next scanning step so that the potential difference between the opposite sides of the organic EL element is equal to a potential that is determined by the Zener diode. In this way, in the following scanning step, after starting the driving operation the organic EL element is illuminated very quickly and the current thereof quickly increases to a level sufficient to obtain a desired high level of brightness. The high level of brightness is retained over a long period of time. Thus, according to the present invention, it is possible to elongate the effective illumination time with the simple configuration, and to retain a high level of brightness.

[0046] The potential of the Zener diode **23** is as high a potential as possible and is a black level of the organic EL element of the illumination color of the pixel. **FIG. 6** is a graph illustrating the relationship between the brightness of an organic EL element and a driving current, with the horizontal axis representing the current flowing through the organic EL element, and the vertical axis representing the brightness. **FIG. 7** is a graph illustrating the relationship between the potential difference and the driving current, with the horizontal axis representing the potential difference in an organic EL element, and the vertical axis representing the driving current of the organic EL element. As illustrated in **FIG. 6**, the driving current and the illumination brightness are in a proportional relationship. With the highest brightness being **I10** in an exponential expression and the driving current at the highest brightness being **I10(10)**. The black level is **1** when the contrast is set to **10**. With the driving current at that time being **I1**, the potential difference of the black level at a contrast of **10** is **V10(1)** when the illumination color is red (R), as illustrated in **FIG. 7**. As illustrated in **FIG. 7**, the relationship between the driving current and the potential difference varies for different illumination colors. Therefore, since the potential difference at the black level varies for different illumination colors, it is necessary to set the retained voltage of the Zener diode illustrated in **FIG. 2** to an appropriate value according to the illumination color. Moreover, the retained voltage of the Zener diode also varies depending upon the desired contrast of the display device. In **FIG. 6**, when the contrast is **100**, the black level is **0.1**, with the highest brightness being **10**. The black level driving current **I100(1)** at a contrast of **100** is $1/10$ of **I10(1)**, and the potential difference of the organic EL element at the black level is **V100(1)**, as illustrated in **FIG. 7**. Therefore, the black level voltage varies depending upon the illumination color and the desired contrast. Therefore, while the voltage to be stored in the Zener diode is as high a potential difference as possible among the black level potential differences, it is appropriately determined depending upon the illumination color and the desired contrast.

[0047] The circuit configuration of the data line driving circuit and the method by which the data line driving circuit supplies the driving current are as in the prior art. **FIG. 8** is a block diagram illustrating an example of a circuit configuration of the data line driving circuit, and **FIG. 9** and **FIG. 10** are timing charts illustrating the column-row timing and the column timing respectively. The driving signal input to a driver interface **30** is input to and latched by a latch **31**, and the driving signal latched by the latch **31** is output to a drive **33** via a D/A converter **32**. Moreover, a control signal is output from the driver interface **30** to the latch **31**, the D/A converter **32** and the drive **33** so as to control the latch **31**, the output timing of the D/A converter **32**, and the precharge operation by the drive **33**. The driving current output from the drive **33** is output to a data line via an output circuit **34**. Typically, a plurality of sets of the driver illustrated in **FIG. 8** are provided for the data lines **3(3a, 3b, 3c, 3d, 3e, etc.)** for supplying the driving current.

[0048] Then, scanning line driving signals are successively turned ON to successively scan the n^{th} and $n+1^{\text{th}}$ scanning lines, as illustrated in **FIG. 9**. A data line driving signal is output in synchronization with the operation of driving the scanning lines. The change of a driving signal for a particular data line is shown. A precharge operation is performed when the driving operation proceeds from a scanning line to the next scanning line. The precharge period in **FIG. 9** and **FIG. 10** is a period during which the switches **25(25a, 25b, 25c, 25d, 25e, etc.)**, illustrated in **FIG. 2**, are turned to the voltage retaining circuit **22** side so that all of the data lines **3(3a, 3b, 3c, 3d, 3e, etc.)** are connected to the voltage retaining circuit **22**. During the precharge period, there is no substantial influence on the current of the driving current source because the amount of charge of the parasitic capacitor is large.

[0049] During the precharge period, the parasitic capacitor of each organic EL element **1** is charged to a black level. When a driving current is supplied after the precharge period, the data line voltage starts increasing immediately because the parasitic capacitor has already been charged, whereby the EL current flowing through the organic EL element **1** accordingly increases to illuminate the organic EL element **1**.

[0050] As described above, according to the present invention, prior to the supply of the driving current, the charge stored in pixels that have been illuminated during the previous scanning step is allowed to flow into the parasitic capacitor of each pixel. In this way the parasitic capacitor of each pixel is charged to a potential equal to or less than a potential that is determined to be a black level. As a result, when the driving current is supplied from the data line driving circuit, the voltage of the data line quickly increases for the selected pixels to initiate the illumination of the organic EL elements. Therefore, a sufficient illumination time to obtain a high brightness is ensured. As a result, it is possible to obtain a high brightness. Moreover, according to the present invention, the effects as described above can be realized only by providing the Zener diode, and connecting each data line to the Zener diode when the scanning operation proceeds to the next scanning line. Thus, it is possible to realize the organic EL display device with a high level of brightness with a very simple circuit configuration. Moreover, the current efficiency is very high because the charge stored in the parasitic capacitors of the organic EL elements

that have been illuminated during the previous scanning step is collected and used to charge the parasitic capacitors of all of the pixels.

What is claimed is:

1. An organic EL display device, comprising:
 - a plurality of organic EL elements arranged in a matrix pattern;
 - a plurality of scanning lines each connected to a row of the organic EL elements;
 - a plurality of data lines each connected to a column of the organic EL elements;
 - a scanning line driving circuit for successively scanning said scanning lines;
 - a data line driving circuit for applying a driving current to a selected data line in synchronization with the scanning operation of said scanning line driving circuit;
 - a Zener diode capable of retaining a voltage in a range for a black level of said organic EL elements;
 - a switch provided between each of said data lines and said Zener diode for either commonly connecting said data lines to said Zener diode or disconnecting said data lines from one another and from said Zener diode; and
 - a control circuit for turning on all of the switches to connect all of the data lines to one another and to the Zener diode when the scanning operation by said scanning line driving circuit proceeds from one scanning line to the next scanning line.
2. The organic EL display device according to claim 1, further comprising a capacitor connected in parallel with said Zener diode.
3. The organic EL display device according to claim 1, wherein said switch selectively connects said data line to said Zener diode or brings said data line into a floating state.
4. The organic EL display device according to claim 2, wherein said switch selectively connects said data line to said Zener diode or brings said data line into a floating state.
5. The organic EL display device according to claim 1, wherein said scanning line driving circuit comprises a scanning line switch, for each of said scanning lines, for selectively connecting said scanning line to a scanning line power source or to a ground.
6. The organic EL display device according to claim 2, wherein said scanning line driving circuit comprises a scanning line switch, for each of said scanning lines, for selectively connecting said scanning line to a scanning line power source or to a ground.
7. The organic EL display device according to claim 1, wherein said data line driving circuit comprises:
 - a signal current source provided for each of said data lines; and
 - a data line power source for applying a driving voltage to said data line via said signal current source.
8. The organic EL display device according to claim 2, wherein said data line driving circuit comprises:
 - a signal current source provided for each of said data lines; and
 - a data line power source for applying a driving voltage to said data line via said signal current source.

9. The organic EL display device according to claim 7, wherein when the scanning operation by the scanning line driving circuit proceeds from the one scanning line to the next scanning line, said control circuit connects a scanning line switch connected to the next scanning line to a ground, connects all scanning line switches connected to the other scanning lines to said scanning line power source, and turns off all of said switches.

10. The organic EL display device according to claim 8, wherein when the scanning operation by the scanning line driving circuit proceeds from the one scanning line to the next scanning line, said control circuit connects a scanning line switch connected to the next scanning line to a ground, connects all scanning line switches connected to the other scanning lines to said scanning line power source, and turns off all of said switches.

11. A method for driving an organic EL display device, wherein said device comprises:

- a plurality of organic EL elements arranged in a matrix pattern;
- a plurality of scanning lines each connected to a row of the organic EL elements;
- a plurality of data lines each connected to a column of the organic EL elements;
- a scanning line driving circuit for successively scanning said scanning lines;
- a data line driving circuit for applying a driving current to a selected data line in synchronization with the scanning operation by said scanning line driving circuit;
- a Zener diode capable of retaining a voltage in a range for a black level of said organic EL elements; and
- a switch provided between each of said data lines and said Zener diode,

said method comprising the step of:

turning on all of said switches to connect all of said data lines to one another and to said Zener diode so as to charge parasitic condensers of said organic EL elements to a voltage that is determined by said Zener diode when the scanning operation by said scanning line driving circuit proceeds from one scanning line to the next scanning line.

12. The method for driving an organic EL display device according to claim 11, wherein a capacitor is connected in parallel to said Zener diode.

13. The method for driving an organic EL display device according to claim 11, wherein said switch either commonly connects said data lines to said Zener diode or disconnects said data lines from one another and from said Zener diode.

14. The method for driving an organic EL display device according to claim 12, wherein said switch either commonly connects said data lines to said Zener diode or disconnects said data lines from one another and from said Zener diode.

15. The method for driving an organic EL display device according to claim 11, wherein said scanning line driving circuit selectively connects each of the scanning lines to a scanning line power source or to a ground by means of a scanning line switch.

16. The method for driving an organic EL display device according to claim 12, wherein said scanning line driving

circuit selectively connects each of the scanning lines to a scanning line power source or to a ground by means of a scanning line switch.

17. The method for driving an organic EL display device according to claim 11, wherein said data line driving circuit controls a driving current to be supplied from a signal current source to said data line.

18. The method for driving an organic EL display device according to claim 12, wherein said data line driving circuit controls a driving current to be supplied from a signal current source to said data line.

19. The method for driving an organic EL display device according to claim 17, wherein when the scanning operation by said scanning line driving circuit proceeds from one scanning line to the next scanning line, a scanning line switch connected to the next scanning line is connected to a

ground, all other scanning line switches are connected to the scanning line power source, and all of said switches are turned off to disconnect said data lines from one another and from said Zener diode.

20. The method for driving an organic EL display device according to claim 18, wherein when the scanning operation by said scanning line driving circuit proceeds from one scanning line to the next scanning line, a scanning line switch connected to the next scanning line is connected to a ground, all other scanning line switches are connected to the scanning line power source, and all of said switches are turned off to disconnect said data lines from one another and from said Zener diode.

* * * * *

专利名称(译)	有机EL显示装置及其驱动方法		
公开(公告)号	US20020036605A1	公开(公告)日	2002-03-28
申请号	US09/962114	申请日	2001-09-26
[标]申请(专利权)人(译)	川岛SHINGO		
申请(专利权)人(译)	川岛SHINGO		
当前申请(专利权)人(译)	川岛SHINGO		
[标]发明人	KAWASHIMA SHINGO		
发明人	KAWASHIMA, SHINGO		
IPC分类号	H01L51/50 G09F9/30 G09G3/20 G09G3/30 G09G3/32 H01L27/32		
CPC分类号	G09G3/3216 G09G2310/0251 G09G2310/0256 G09G2320/043 G09G2330/023		
优先权	2000297498 2000-09-28 JP		
其他公开文献	US6650308		
外部链接	Espacenet USPTO		

摘要(译)

有机EL元件以矩阵图案排列。一列有机EL元件通过它们的阳极连接到每条数据线。一排有机EL元件通过它们的阴极连接到每条扫描线。在数据线驱动电路中，信号电流源连接到每条数据线，并且每个信号电流源连接到电源。在扫描线驱动电路中，开关连接到每条扫描线，每个开关的一端连接到电源，而另一端连接到地。数据线通常通过开关连接到电压保持电路的齐纳二极管。电容器与齐纳二极管并联连接。齐纳二极管保持的电位尽可能高，使得确定为每种颜色的黑色电平。

